

Flat pattern M 1:5  
(K-factor: 0.5)

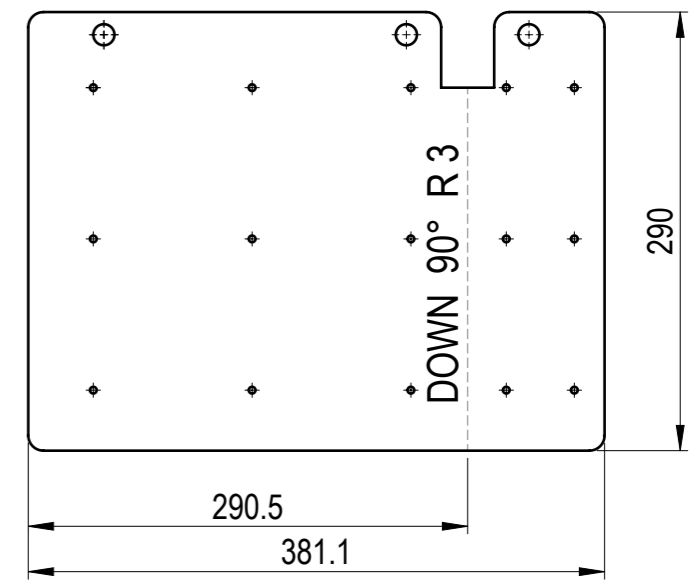

Other dimensions from .DXF file.

SHEET METAL INFORMATION	
Length, mm	381.1
Width, mm	290
Thickness, mm	3
Inside Bend Radius, mm	3
K-Factor	0.5
No. of Bends	1

<b>WEMPS</b> ENGINEERING SERVICES	MATERIAL	WEIGHT	DEBURR AND BREAK SHARP EDGES DO NOT SCALE DRAWING		REVISION	DATE
	S355JR	2.537 Kg				21.03.2025
	SURFACE PROTECTION	MACHINING	THERMAL CUTTING	WELDING	SCALE	FORMAT
	HDG EN ISO 1461	ISO 2768 mK	ISO 9013 441	ISO 13920 BF	1:3	A3
	NAME	SIGNATURE	PART NO.			
Designed by	M. Supols		105-11320-02			
Drawn by	M. Supols		DESCRIPTION			
Technical ref.			Angle 2-2			SHEET 1/1